



Barton Hill Settlement
43 Ducie Road Barton Hill Bristol BS5 0AX
Tel: 0117 377 3166
email: info@travellinglighttheatre.org.uk
www.travellinglighttheatre.org.uk

Van Hire Details

The van can only be hired for charitable use.

These rates are only for use within the UK.

Rates: Standard rate: £50 + VAT per day or £300 + VAT per week.
Associate rate: £40 + VAT per day or £250 + VAT per week.
These rates are open to negotiation (especially for longer periods).

Insurance: Any driver aged between 21 and 74 inclusive and holding a full UK driving licence, will be covered by our comprehensive insurance (at no extra cost).

Our insurance company must be notified of any current motoring convictions, accidents and medical conditions that may impair driving ability.

The hirer will be responsible for paying any excess charges: £150 general excess and £75 windscreen excess.

VAN SPECIFICATION

General: 313CDI Long Wheel Base Mercedes Sprinter

Registration: WR11 NSY

Length: 6.68m Width: 1.93m Height: 2.72m

Fuel: Diesel

Manual gears (6 speeds)

Alarm and reverse bleeper fitted

Cab area: Seats 6 including the driver. This number must not be exceeded.

Coat hooks on bulkhead

Individual light above passenger seats

CD player

Cargo area: Separate cargo compartment: 3.00m long x 1.70m wide x 1.80m high (ceiling tapers in slightly and boxed off wheel arches reduce width to 1.24m in centre).

Removable rails for hanging lights/costumes or for securing cargo

Interior and Exterior lights



Image from Van Log with Dimensions

Mercedes Sprinter 313CDi Van ELWB High Roof (2005)

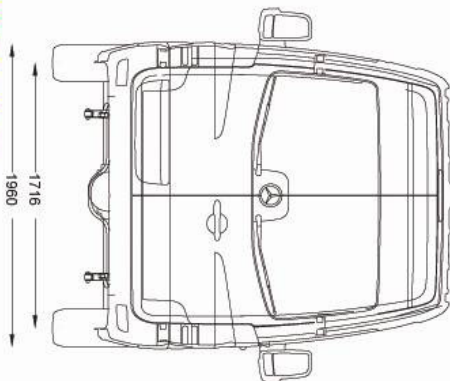
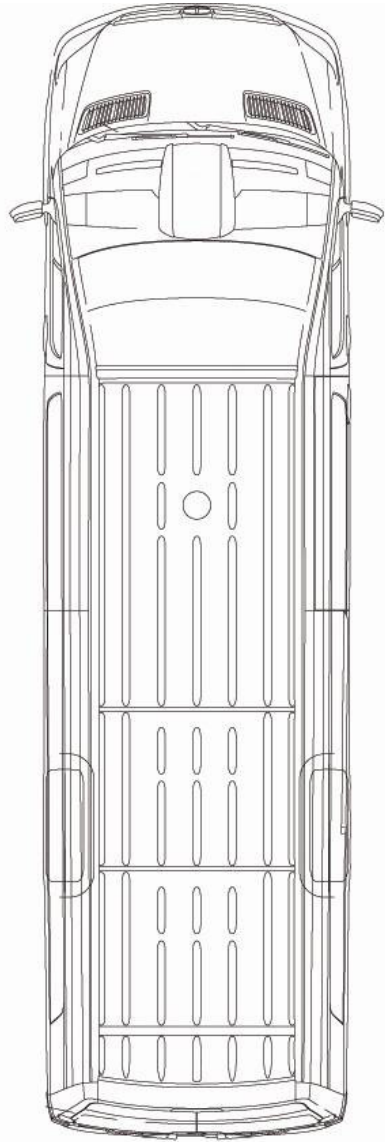
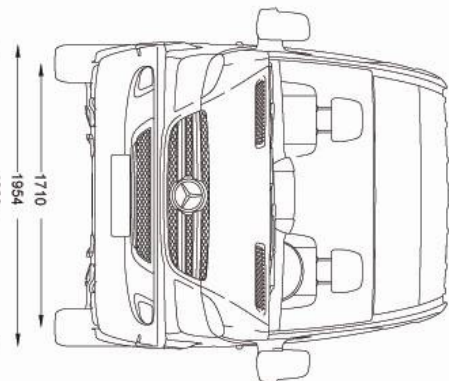
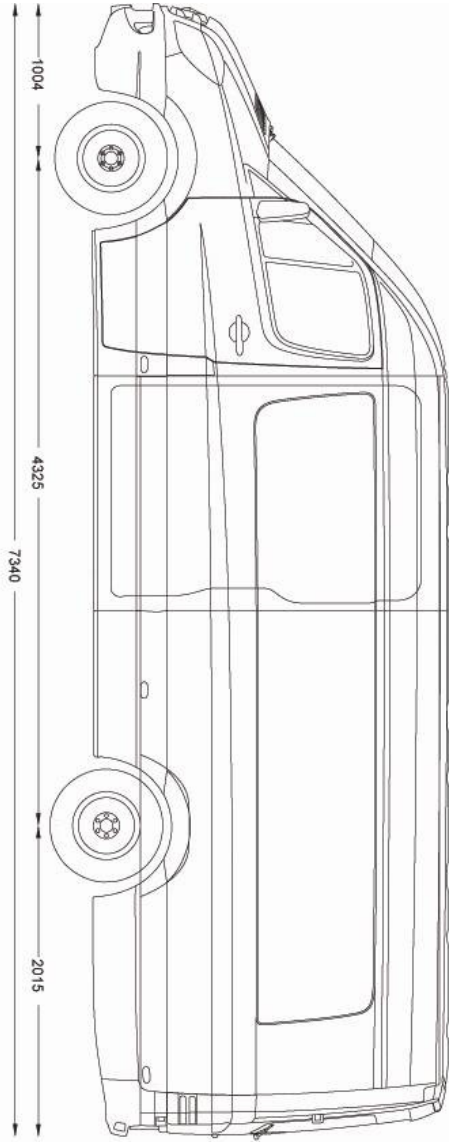

All measurements in millimeters.

© 2000 - 2010 Onno van Braam, www.the-blueprints.com
The largest free 3-view, template and blueprint collection on the internet.

